

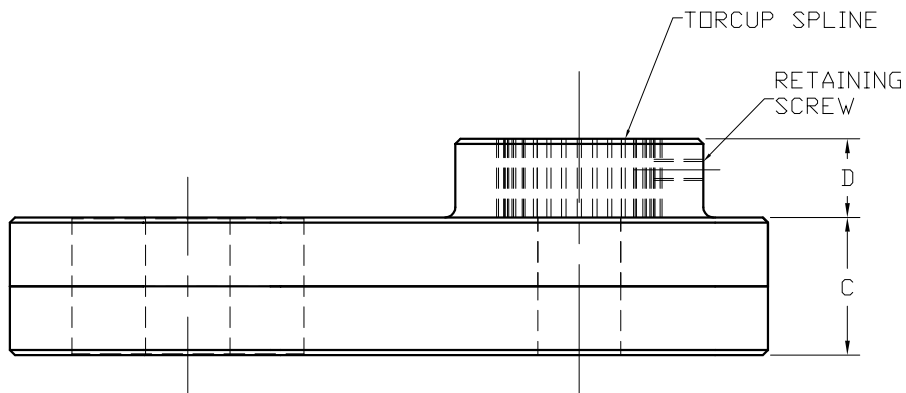

## OFFSET GEARBOX DIMENSIONS FOR RAPTOR PNEUMATIC TOOLS

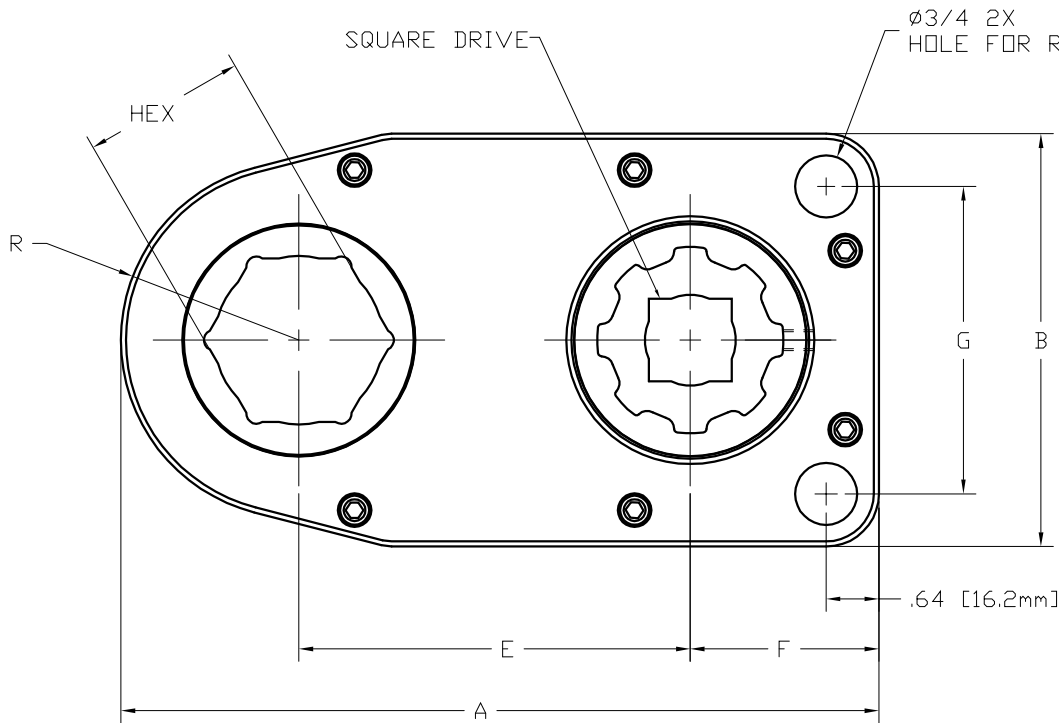

| RAPTOR 500 |               | 3/4" SQUARE DRIVE |       |       |       |       |       |       |       |       |
|------------|---------------|-------------------|-------|-------|-------|-------|-------|-------|-------|-------|
| LINK #     | MAX. HEX SIZE |                   | A     | B     | C     | D     | E     | F     | G     | R     |
|            | [in.]         | [mm]              | [in.] | [in.] | [in.] | [in.] | [in.] | [in.] | [in.] | [in.] |
| 1          | 2-3/16        | 55                | 9.18  | 5.00  | 1.25  | 1.06  | 4.74  | 2.28  | 3.72  | 2.16  |
| 2          | 3-1/8         | 80                | 11.76 | 5.56  | 1.25  | 1.06  | 6.20  | 2.78  | 4.29  | 2.78  |

| RAPTOR 1000 / RAPTOR 2000 / RAPTOR 3000 |               | 1" SQUARE DRIVE |       |       |       |       |       |       |       |       |
|---|---------------|-----------------|-------|-------|-------|-------|-------|-------|-------|-------|
| LINK #                                  | MAX. HEX SIZE |                 | A     | B     | C     | D     | E     | F     | G     | R     |
|   | [in.]         | [mm]            | [in.] | [in.] | [in.] | [in.] | [in.] | [in.] | [in.] | [in.] |
| 1                                       | 2-3/16        | 55              | 9.18  | 5.00  | 1.67  | 1.11  | 4.74  | 2.28  | 3.72  | 2.16  |
| 2                                       | 3-1/8         | 80              | 11.76 | 5.56  | 1.67  | 1.11  | 6.20  | 2.78  | 4.29  | 2.78  |
| 3                                       | 3-3/4         | 95              | 12.99 | 6.31  | 1.67  | 1.11  | 6.68  | 3.16  | 5.04  | 3.16  |

| RAPTOR 6000 |               | 1 1/2" SQUARE DRIVE |       |       |       |       |       |       |       |       |
|-------------|---------------|---------------------|-------|-------|-------|-------|-------|-------|-------|-------|
| LINK #      | MAX. HEX SIZE |                     | A     | B     | C     | D     | E     | F     | G     | R     |
|             | [in.]         | [mm]                | [in.] | [in.] | [in.] | [in.] | [in.] | [in.] | [in.] | [in.] |
| 1           | 3-3/4         | 95                  | 13.82 | 6.54  | 2.08  | .92   | 7.31  | 3.24  | 5.04  | 3.27  |