

TU

ACCESSORY



END CAP PROTECTOR

TU Series Square Drive
Hydraulic Torque Wrench Accessory

IP
torque

TU Series Square Drive Hydraulic Torque Wrench - End Cap Protector

MODEL#	PART #	LENGTH 1 (IN/MM)	LENGTH 2 (IN/MM)	MAX DIAMETER (IN/MM)	MIN DIAMETER (IN/MM)
TU-2	ATU-2-03-EC	0.52/13	0.89/23	2.00/51	1.09/28
TU-3	ATU-3-03-EC	0.75/19	1.13/29	2.63/67	1.43/36
TU-5	ATU-5-03-EC	0.97/25	1.22/31	3.13/79	1.68/43
TU-7	ATU-7-03-EC	1.03/26	1.48/38	3.50/89	1.93/49
TU-11	ATU-11-03-EC	1.13/29	1.66/42	3.95/100	2.18/55
TU-20	ATU-20-03-EC	0.54/14	0.46/12	2.95/75	2.68/68
TU-27	ATU-27-03-EC	1.50/38	2.11/54	5.25/133	2.87/73
TU-60	ATU-60-03-EC	1.65/42	2.83/72	5.50/140	3.87/98

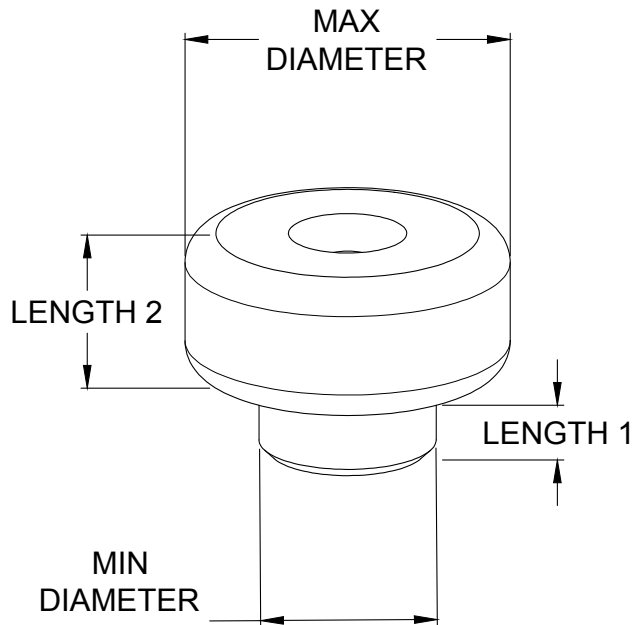

TU Series - End Cap Protector

This accessory provides protection for the end cap when operating the tool without the reaction arm. This is a non-reaction accessory.

