

**RP**  
**VT**

# ACCESSORY



## **HORIZONTAL TOOL HANGER**

RP RAPTOR Series, VT VOLTA Series  
Pneumatic Torque Wrench Accessory  
Battery Torque Wrench Accessory

*LIPTORQUE*

MODEL NUMBER	PART NUMBER	A (IN/MM)	B (IN/MM)	C (IN/MM)
RP/VT-500	RPA-TCH-05-H	1.00/25.4	4.13/104.8	5.47/139.1
RP/VT-1000, 1000-1 1000E6 & 3000	RPA-TCH-10.30-H	1.00/25.4	4.13/104.8	5.47/139.1
RP/VT-2000	RPA-TCH-20-H	1.00/25.4	4.13/104.8	5.47/139.1

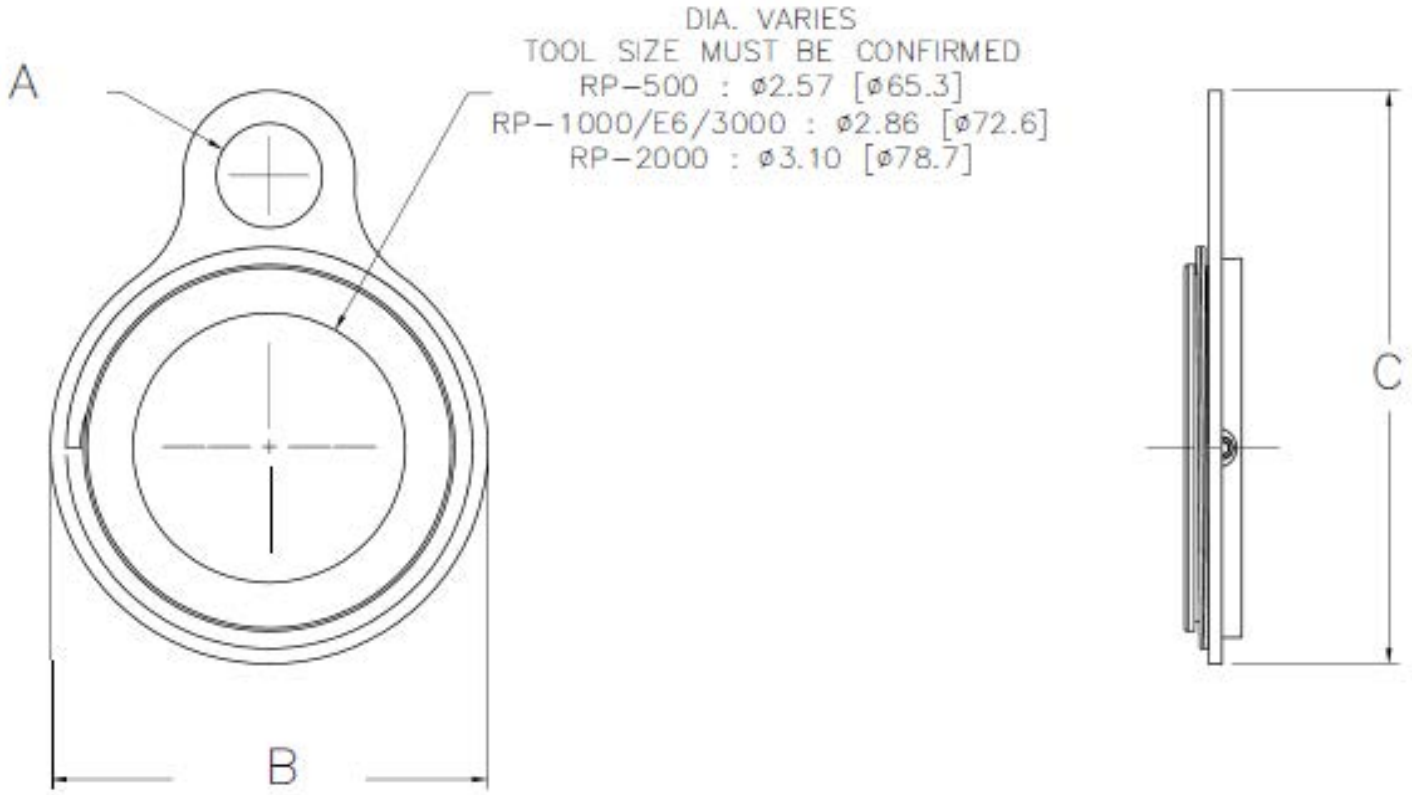

RP/VT-500, 1000, 1000-1, 1000E6 and 2000 can be field installed.  
RP/VT-3000 requires factory installation.

